



'Tradie Tuff'

COMMERCIAL ROOF RACKS

FORD RANGER WILDTRAK, 06/2012 - ON

ROLLER SHUTTER FIXED MOUNT

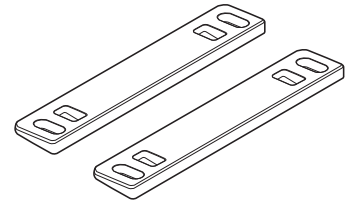

PART NUMBER: VAS.RC1077, VAS.RA1077, VAS.RC1079, VAS.RA1079.

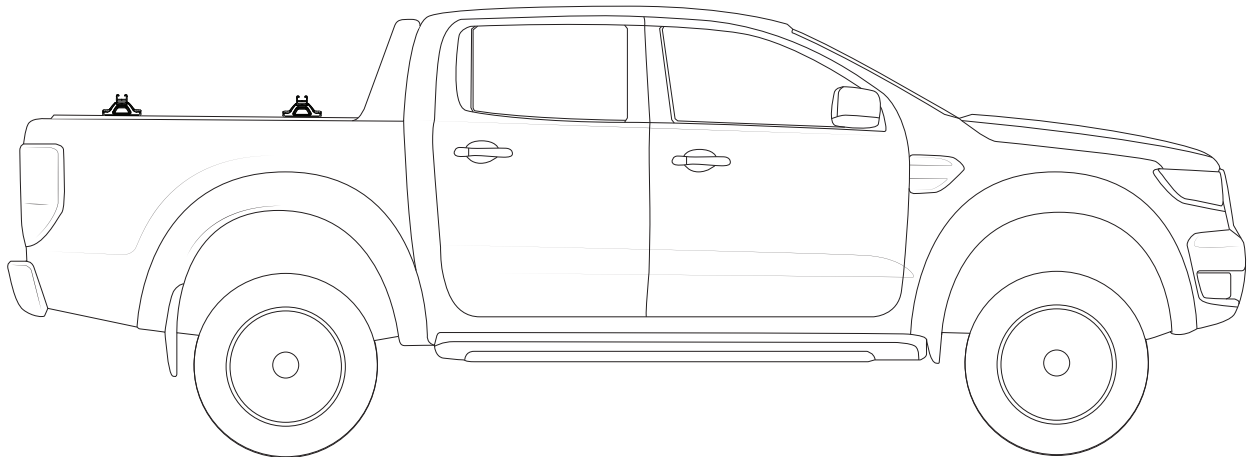

Note:

- PLEASE READ INSTRUCTIONS AND CHECK CONTENT PRIOR TO INSTALLING.
- PLACE INSTRUCTIONS IN VEHICLES GLOVE COMPARTMENT AFTER INSTALLING.



2 Bar maximum capacity: 100kg

Tested to AS/NZS 1235-200 ADR standards

- Please check your vehicle's manual for vehicle load capacity (please do not exceed the lowest load rating) and please download and read our Load Rating guide which can be found on our website vas.com.au.
- Load rating is based on driving on sealed roads to road conditions and includes weight of roof rack system.

Important information

- Complete maintenance checks weekly including bolt connections and tightness.
- Heavy loads carried near feet
- Overhanging loads should conform to relevant state laws
- Check tie down strap tension every 50klm as loads can shift
- Specialised equipment carriers such as ladder slides should be used
- Ensure your roof racks, ladder rails and or load does not inhibit the tailgate lifting on vehicles manufactured with these doors
- Check car park heights before entering
- Keep load under the maximum capacity
- Use non stretch fastening straps
- Remove roof racks prior to using an automatic car wash

Note: The handling characteristics of a vehicle will change when a carrier system is fitted. Driving technique such as speed reduction, cornering techniques and braking distances should be altered to allow for these changes.

Kit Inclusions

Item	Part	Qty
1	M6 x 30mm button screw - F008	8
2	M6 spring washer - F012	8
3	M6 x 16mm flat washer - F011	8
4	M6 square nut 15x18x7mm - F057	8
5	Wedge - C136	4
6	4mm allen tool - C026	1

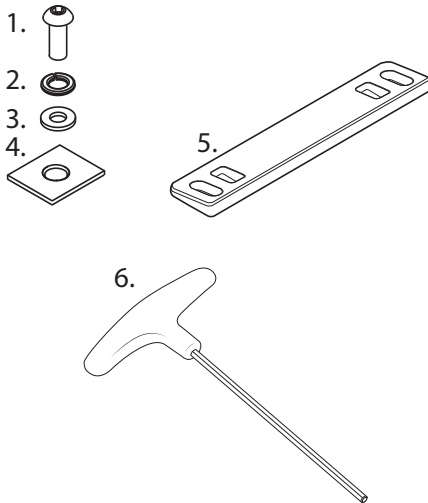

Tools Required

- 1 - 17mm spanner.
- 2 - 4mm allen key (provided).

Required kits (as separate):

- Crossbar 1500mm
- Crossbar Mount kit

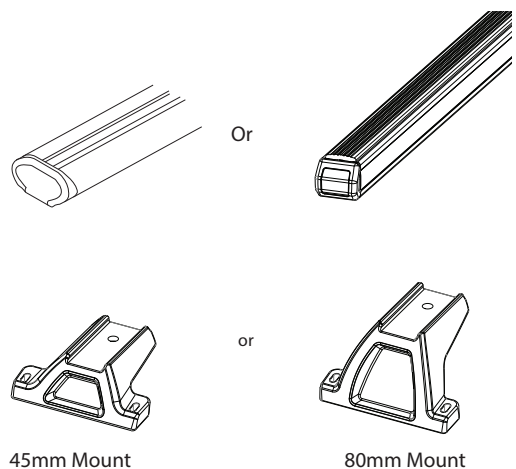

Step 1

Move to the rear of the vehicle and locate the rubber plugs. They are closest to the cabin, in the tub roller shutter. Carefully remove the plugs.

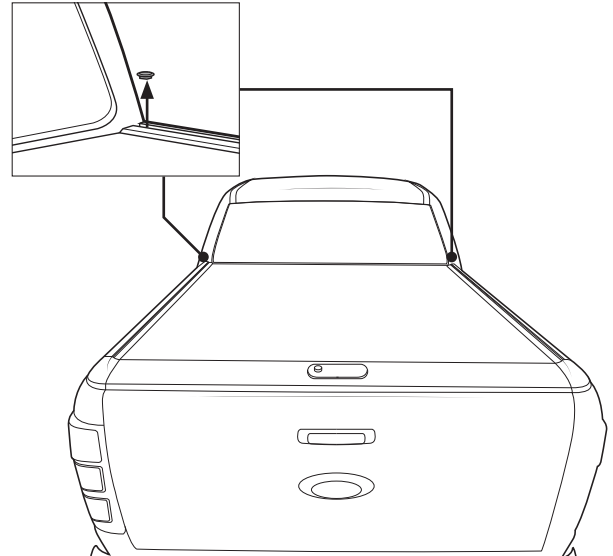
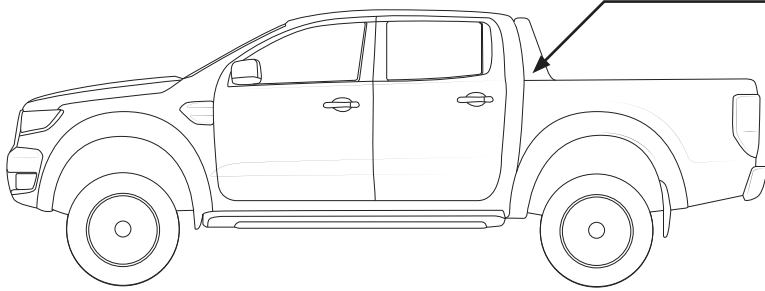

Step 2

With the rubber plugs removed, slide 4x M6 channel nuts, per side, into the channels.

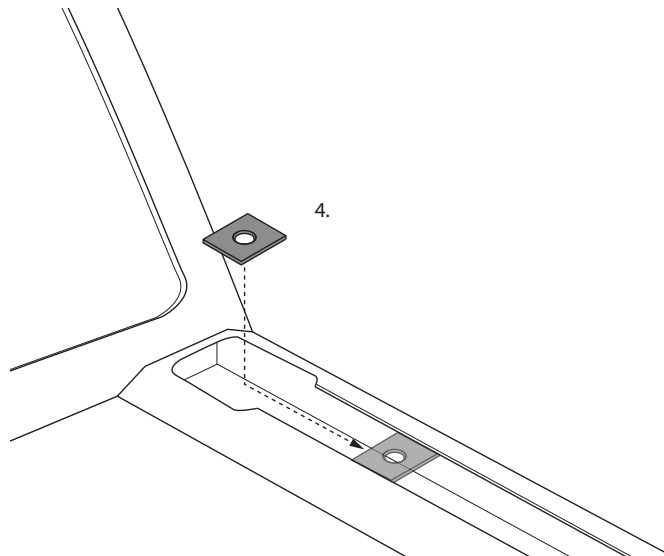

Step 3

Place a wedge over each installed channel nut. Mount kits can now be fit in place with the hardware provided. Finger tighten only at this stage.

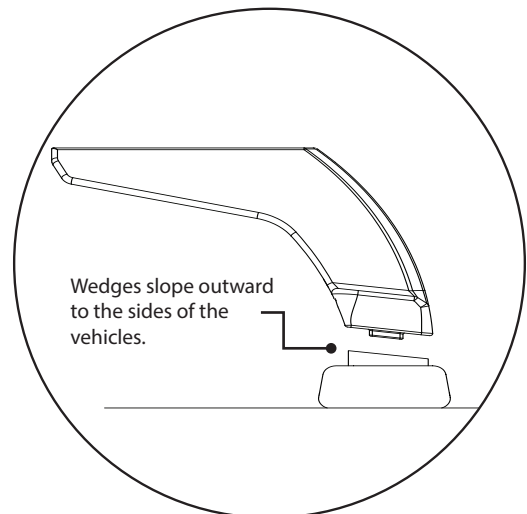
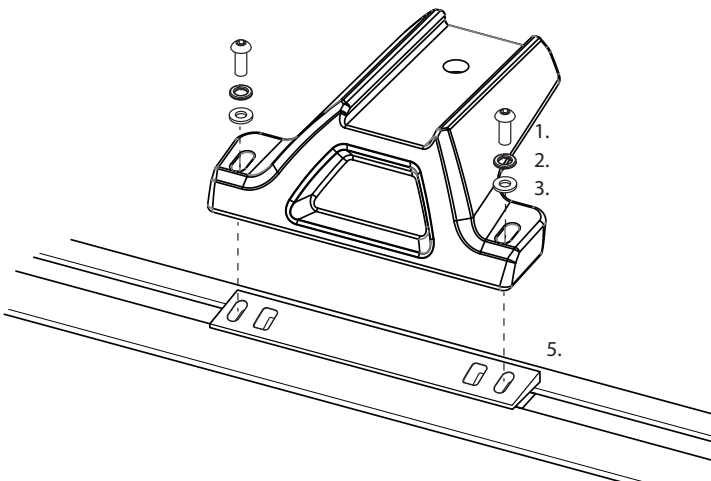

Step 4

- 1 - Fit the chosen crossbar style to the mount kits.
- 2 - Position the crossbars in their intended position and tighten in place with the allen key provided.
- 3 - Make sure the crossbars are spaced evenly on the mounts and tighten with a 17mm socket wrench (8-10Nm).

